

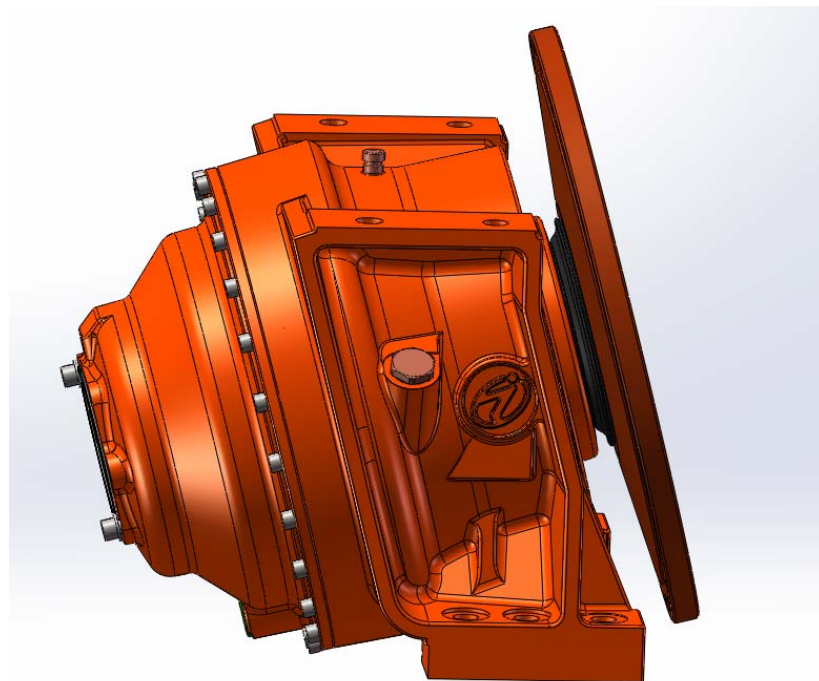

## Gearbox Instruction Manual

### IFT075D3130



**Qindao Infinity Precision - Machine Co., Ltd**

**Add: 1# Nanhai Road, Nancun Industry Zone, Pingdu City, Qingdao, China**

**Tel: 0086-0532-83395326**

**0086-0532-68723515**

**Fax: 0086-0532-83395108**

**索引：****Index:**

1. 技术参数	Technical data
2. 外型特征	Configuration
3. 减速机安装固定方法	Gearbox fixing details
4. 减速机吊装	Gearbox raising
5. 运输过程保护措施	Transportation protective measures
6. 维护保养	Maintaining
7. 故障排除	Troubleshooting
8. 备件订购	Spare Parts Order

**安全须知：**

本手册只对产品进行总体介绍，只供有熟练技巧的技术人员在有适当工具（适当设备）的条件下应用。

**注意：**减速机有很多重量很大的零部件组成；请应用合适的吊装设备确保部件及人身安全。

**注意：**正常工况下减速机的工作温度不应超过 100° C。如超过此温度，请停止使用减速机并对温度进行冷却。

**Safety regulation:**

This handbook gives just an overall view of the gearbox unit and is addressed to skilled workman with proper tools (properly equipped).

ATTENTION: Gearbox is made with heavy parts: secure the parts and use proper lifting equipment.

ATTENTION: Under normal working conditions the gearbox shall never exceed a temperature of 100° C. If this temperature limit is exceeded it is recommendable to suspend usage and allow the gearbox to cool down.

## 1. 技术参数 Technical data

本减速机为固定减速比三级减速。

This gearbox has three reduction stages.

法兰径向最大载荷	KN	150	Max radial force on flange
法兰轴向最大载荷	KN	50	Max axial force on flange
最大输入速度	rpm	2500	Max input speed
传动比		130	Available ratios
最大输出扭矩	Nm	75000	Max output torque
水泥钢罐容积	m <sup>3</sup>	10-12	Drum capacity
水泥钢罐最大安装角度	°	15	Max drum installation angle
最大法兰偏角	°	± 6	Max flange misalignment
齿轮油型号		SAE 85W90-API GL5	Gearbox oil type
减速机加油量	L	到油位 (Reach oil level)	Gearbox oil quantity
减速机换油周期	Hours	1500	Gearbox oil changing interval
减速机重量	Kg	286	Gearbox weight

## 2. 外型特征 Configuration

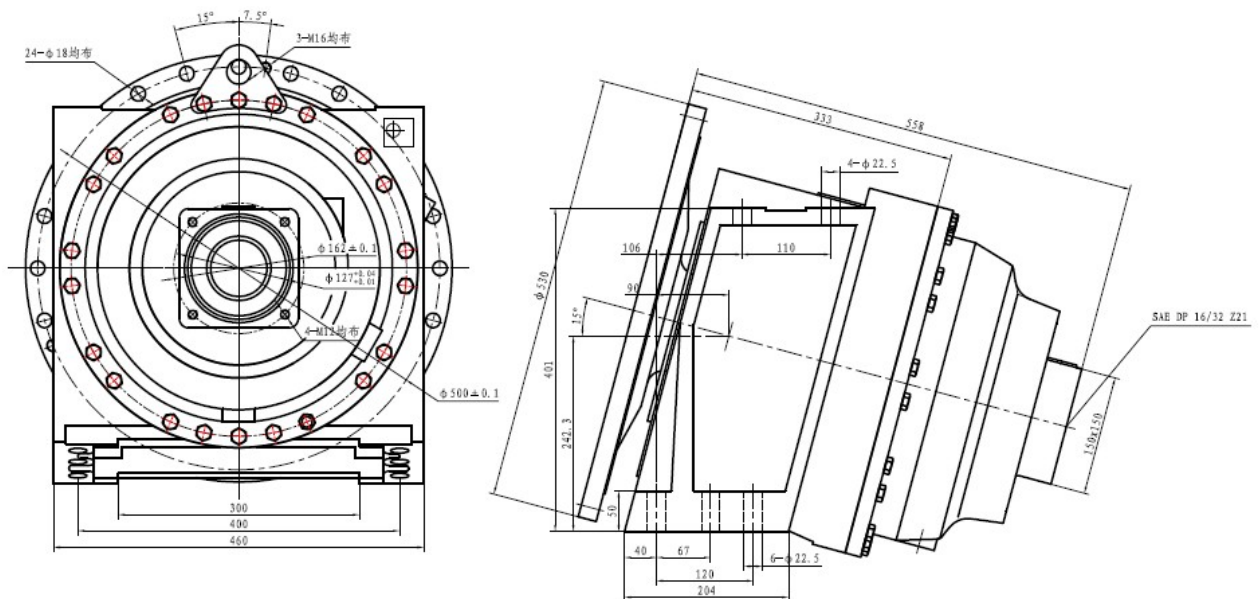

### 3.减速机安装固定方法 Gearbox fixing details

减速机与水泥罐之间由 24 个固定于法兰盘的 M16 的螺栓固定(参看图 1)。

此 24 个螺栓的拧紧力矩必需满足 10.9 级 M16 螺栓的最小拧紧力矩要求。拧紧力矩必须大于 300Nm。减速机输出联结法兰盘轴端采用可调心滚柱轴承，联结法兰盘轴与减速机内传动部件连接方式为鼓花键联接。此种解决方案可保证减速机主轴与法兰盘法兰轴在不同心的状况下也会有扭矩传输到水泥罐，保证设备的正常使用。

可能发生上述减速机主轴与联结法兰不同心的状况的情况如下：在水泥罐车正常使用过程中、在罐车车架弯曲变形的状况下。为了确保安全，法兰盘最大偏角由机械止动装置限定为  $\pm 6^\circ$  (参看图 2) 在任何状况下，最佳安装方案为法兰盘无偏角或只有极小偏角。

The gearbox is fixed on the drum by 24 M16 screws, placed on the centring flange (see fig. 1).

The 24 screws must submit a minimum resistance class equal to 10.9. The tighten torque required should not be less than 300Nm..

The support flange of the drum is keyed on a selfaligning roller bearing and it is connected to the gearbox group by a toothed joint.

This solution allows the gearbox to transmit the torque to the drum even if the flange and the main axle of the gearbox are not perfectly aligned: this could happen due to “mistakes” in the joinery and for the bending of the frame and of the drum in the working conditions.

For safety reasons the max misalignment is limited to  $\pm 6^\circ$  by a mechanical stop (fig. 2). In any case the best assembly solution is the one with little or no misalignment.

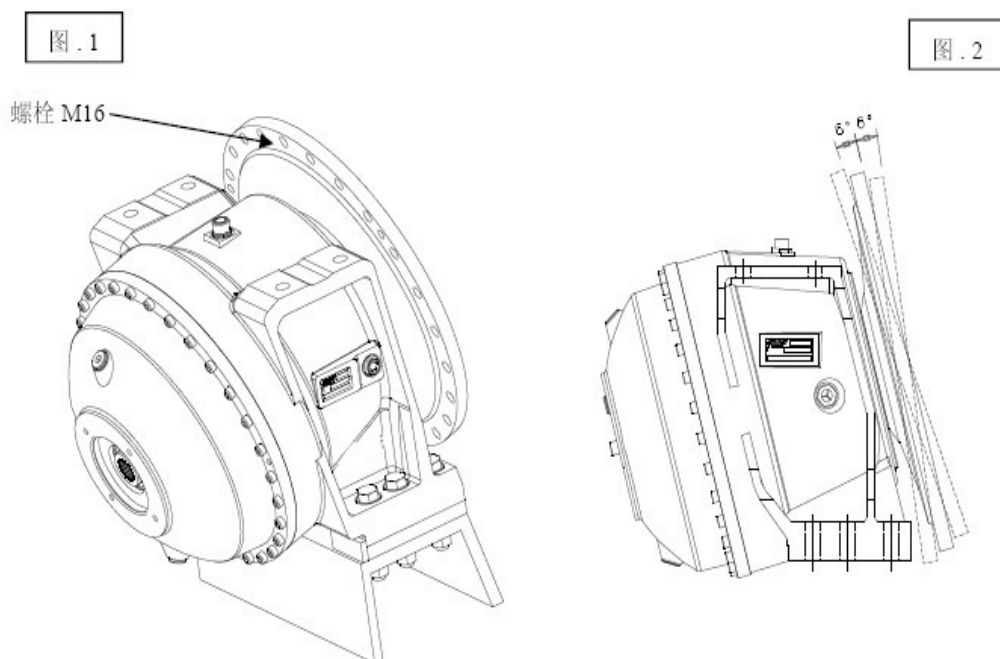

减速机由 6 个 M20 的螺栓固定于车架减速机固定架(图 3).

车架减速机固定架需满足的技术要求:平面度为 0.15 mm.表面粗糙度为 12.5 μm. (图 4).

6 个 M20 减速机固定螺栓的拧紧力矩必需满足 10.9 级 M20 螺栓的最小拧紧力矩要求(每侧三个螺栓 ). 拧紧力矩必须大于 600Nm。

此 6 个螺栓及其配套螺母要与垫圈配合应用 (图 3 和图 4)。

在车架减速机安装台面减速机安装座输入轴端两侧焊接金属挡块来确保减速机无水平面前后方向的相对位移(图 3 和图 4)。

The gearbox is fixed on the drum by 6 M20 screws (see fig.3).

You should prepare a frame support with surfaces belonging to the same plane and with a flatness of 0.15mm and a superficial average roughness about 12.5 μm. (see on fig.4).

You must fix the gearbox on the frame by 6 M20 screws (tree for each side) with a minimum resistance class equal to 10.9. The tighten torque required should not be less than 600Nm.

You must use washers for screw and nuts (see Fig.3 and 4).

A complete installation requires to weld on the frame a mechanical stop, one for each side, previously placed in beat on the gearbox (Fig. 3 and 4).

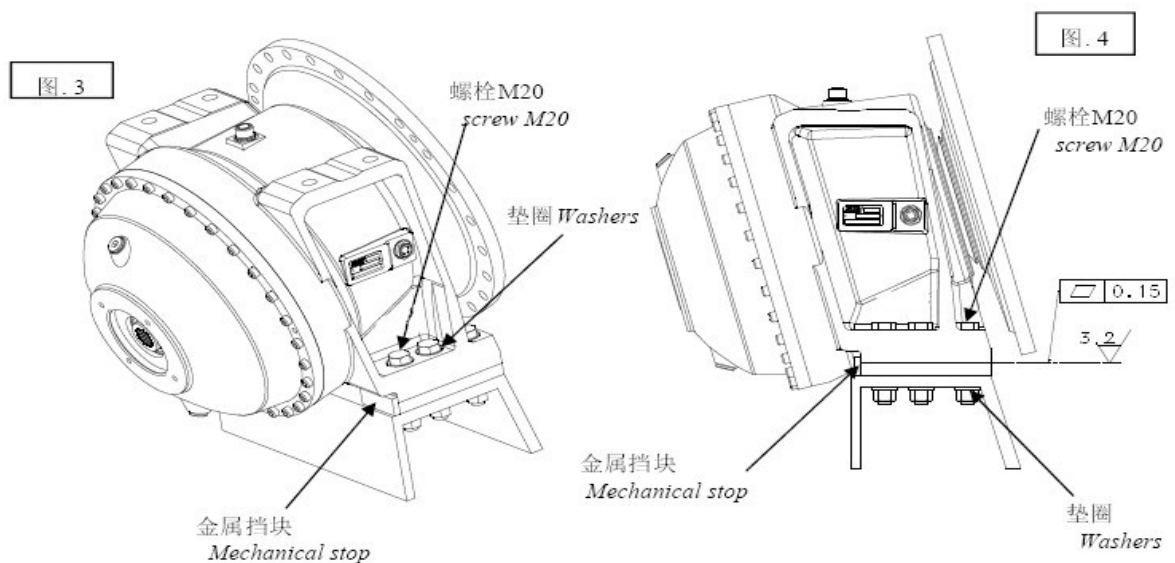

#### 4.减速机吊装 Gearbox raising

禁止应用吊带或吊链捆绑于法兰盘与减速机的结合部起吊减速机(如图 5)。推荐方案为把吊带或吊链用吊钩固定于减速机上表面的壳体孔进行吊装。(图 6 中的 A 孔)

Absolutely avoid to position straps or chains between the flange and the housing (fig. 5) to raise the gearbox. It is recommended to hook straps or chains at the holes (A in fig. 6) on the upper surface of the housing.

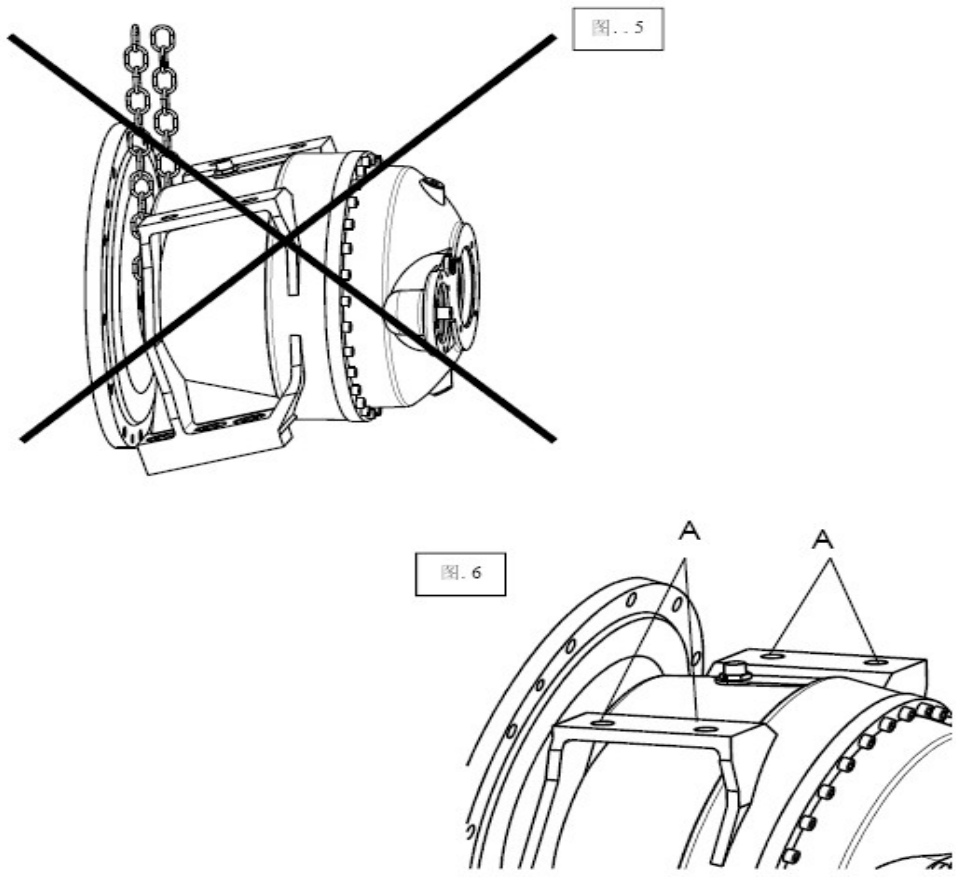

#### 5.运输过程保护措施 Transportation protective measures

减速机装有运输过程保护装置。

请注意：在装配马达与水泥罐之前移去保护装置。您需要移去：

- 马达输入轴保护盖；

The gearbox is supplied with some protection devices in order to protect it while carrying.

Please, pay attention: remove the protection devices prior to connect the motor and the drum.

You have to remove:

- The motor pinion protection .

#### 6 维护保养 Maintaining

本章指出了日常维护工作及其相关安全措施。

- 不可接触旋转部件。



●如果要进行维护工作，应停机。

维护与保养工作

●将废弃油收集于合适的容器中，处置废油应符合相关规定。

机械设备的工作寿命可通过适当的维护与保养措施而得到相当大的提高。

每日进行目视检查，特别检查减速机的密封性。

定期查看减速机有无异常噪音。

定期检查油位（油标或者油位螺塞）

按照保养日程表的规定更换润滑油。

工作 150 小时后进行第一次换油。

每工作 1500 小时或 12 个月后（按最早者）更换一次润滑油。

至少每月检查一次所有螺钉和螺栓的紧固性。

**减速机保养日程表**

工作 150 个小时后	第一次换油
每周	目视检查 检查异常噪声 检查油位
每月	检查所有螺钉及螺栓的紧固性
每半年	检查油质
每年（或工作 1500 小时后，按最早者）	更换润滑油

注意：●加油或更换油后，请将油位螺塞及放油螺塞拧紧，否则将可能会导致漏油或渗油。

This chapter points out routine maintenance work and related security measures.

Do not touch rotating parts.

If carry out maintenance work, the gearbox must stop working.

Maintenance and Care Work

The waste oil is collected in a suitable container, the dispose of waste oil shall comply with relevant regulations.

Machinery equipment working life through proper care and maintenance measures can obtain considerable improvement.

Daily visual inspection, particularly check seal performance of the gearbox.

Regularly check abnormal noise.

Regularly check the oil level. (oil mark or oil level plug)

Oil change according to the maintenance and care schedule.

The first oil change after 150 operating hours.

After each 1500 hours or 12 months (at the earliest) change oil.

At least once a month check all the screws and bolts fastening.

Gearbox Maintenance and Care Schedule

After 150 working hours	The first oil change
Every week	Visual inspection Check abnormal noise Check oil level
Every month	Check all the screws and bolts fastening and its tightness.
Every 6 months	Check oil quality
Evry year (or every 1500 hours (at the earliest))	Oil change

Attention: Whenever after add oil or replace oil, please tighten the oil level plug and the oil drain plug, otherwise this may result in oil leakage.

**7 . 故障排除 Troubleshooting**

下面表格中的资料是供协助查找和排除缺陷和故障。在某些情况下，问题可能是由于安装了减速机的机器或者设备引起的，所以查找和排除那些故障就要参见机器或者设备制造厂家的说明书。

故障	原因	排除方法
轴承温度过高	润滑油面过低	润滑加满至油位
	润滑油的质量老化	更换润滑油
	轴承缺陷	更换轴承
操作油温过高	润滑油面过低	检验油面高度
	润滑油的质量老化	更换润滑油
	润滑油中有污染物	更换润滑油
运行中异常噪声	齿轮损坏	请与供应商联系
	轴承轴向间隙过大	请与供应商联系
	轴承缺陷或磨损	请与供应厂商联系
	施加负载过大	请将负载调整至减速机可承受范围运行。
	润滑油中有污染物	更换润滑油
安装减速机时有异常噪声	安装螺栓松动	螺栓紧固至规定扭矩
	安装螺栓磨损	更换螺栓
漏油	润滑油油面过高	检验油面高度
	密封件老化或损坏	更换
	壳体联结之间螺栓未拧紧	螺栓紧固至规定扭矩
减速机不运行或运行困难	油黏度过高	更换
	油面过高	检查油面高度
	施加的负载过大	请将负载调整至减速机可承受范围运行。



输出不转动而原动机转动	齿轮损坏	请与供应厂商联系
-------------	------	----------

注意：如有不明之处，请及时与供应商联系！

Data in the table below is for assistance in locating and troubleshoot defects and faults. In some cases, the problem may be due to the machine or device which are matched with the gearbox, so if want to find and exclude those faults, people have to see those machines or devices manufacturer's instructions.

Faults	Reason	Troubleshooting method
Bearing temperature is over high	Oil level is over low	Add oil to the level
	Quality of lubricating oil aging	Change oil
	Bearing defective	Change bearing
Operation oil temperature is over high	Oil level is over low	Check oil level
	Quality of lubricating oil aging	Change oil
	Contaminants in the oil	Change oil
Abnormal nosie	Gear damage	Contact the supplier
	Bearing axial clearance is too large	Contact the supplier
	Bearings defective or worn	Contact the supplier
	Excessive load is applied	Please adjusted the load range to the range the gearbox can bear.
	Contaminants in the oil	Change oil
Abnormal noise in process of gearbox mounting	Mounting bolts loose	Tighten bolt to the specified torque
	Mount bolt worn	Change bolt
Oil spill	Oil level is over low	Check oil level
	Seals aging or damaged	Change seals
	Bolt in connection between the housings is not tightened	Tighten bolt to the specified torque
Gearbox don't runs or runs difficultly	Oil viscosity is over high	Change oil
	Oil level is over high	Check oil level
	The applied load is too large	Please adjusted the load range to the range the gearbo x can bear.
Output does not rotate while the prime mover rotates	Gear worn	Contact the supplier

Attention: If anything is unclear, please contact the supplier!

## 8. 备件订购 Spare Parts Order

备件必须符合本公司规定的技术要求。本公司提供的原始备件总是符合这些要求的。  
订购备件请与本公司销售中心联系。

联系电话(Tel): 0532-83395326

传真 (Fax) : 0532-83395108

地址(Address): 山东青岛平度市南村工业园南海路 1 号

邮编 (P.C.) : 266736

Spare parts must comply with the technical requirements of our company. Original spare parts provided by our company are always meet these requirements.

If order spare parts, please contact sales department of our company.

Tel.: +86-532-83395326

+86-532-68723515

Fax: +86-532-83395108

Address: 1# NanHai Road, NanCun Industry Zone, PingDu City, Qingdao, China

P.C.: 266736

Appendix A: Bolt tightening torque form

Bolt specification (mm)	Bolt strength level tightening torque(Nm)			
	4.6	8.8	10.9	12.9
6	4~5	9~12	13~14	15~20
8	10~12	22~29	29~35	37~50
10	20~25	44~58	64~76	74~88
12	35~44	76~102	108~127	128~171
14	54~69	121~162	176~206	204~273
16	88~108	189~252	274~323	319~425
18	118~147	260~347	372~441	489~565
20	167~206	369~492	529~637	622~830
22	225~284	502~669	725~862	847~1129
24	294~370	638~850	921~1098	1096~1435
27	441~519	933~1244	1372~1617	1574~2099
30	529~666	1267~1689	1666~1960	2138~2850
36	882~1078	2214~2952	2744~3283	3736~4981
42	1372~1666	3540~4721	4263~5096	5974~7966
48	2058~2450	5311~7081	6468~7742	8962~11949

Attention: If special requirements or specifications are not in this form, please refer to the relevant technical data or standards.

Appendix B: Technical Drawing

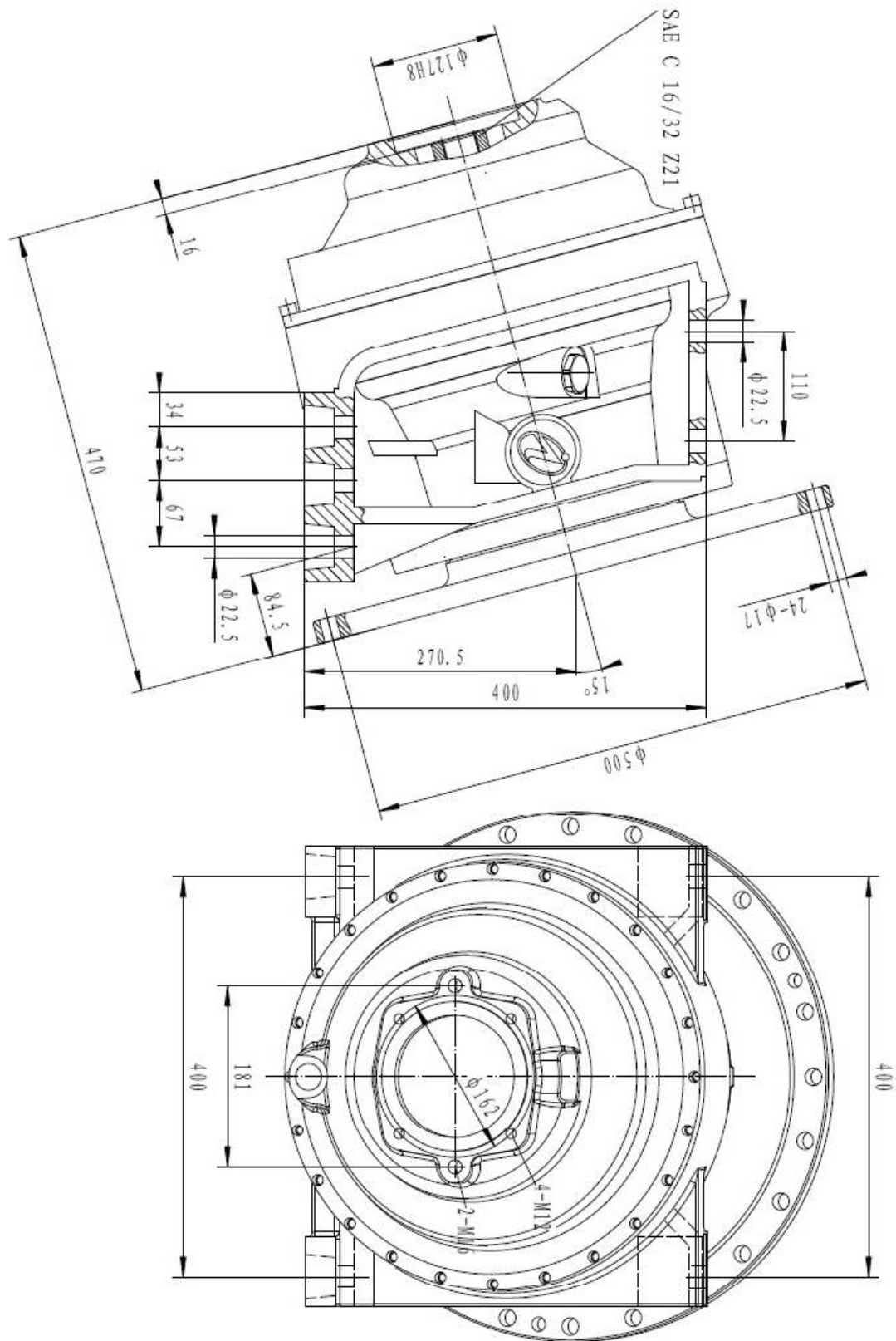

Appendix C: Product Quality Certification

Product Quality Certification

NAME: Planetary gearbox

TYPE: \_\_\_\_\_

MANYFACTURED NUMBER: \_\_\_\_\_

The gearbox passes inspection, approved for leaving factory.

INSPECTOR: \_\_\_\_\_

DATE: \_\_\_\_\_

QINGDAO INFINITY PRECISION-MACHINE CO., LTD

SALES: Tel.: +86-532-83395326

+86-532-68723515

